

NOTES:

- 1.) Post size depends on fence height and wind loads. See MONTAGE PLUS™ post sizing chart.
- 2.) Third rail required for Double Rings.
- 3.) Available in 3" air space and/or Flush Bottom on most heights.

RAKING DIRECTIONAL ARROW

Welded panel can be raked 30" over 8' with arrow pointing down grade.

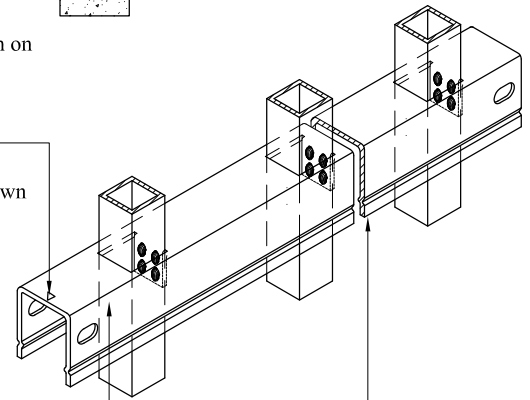

PROFUSION™ WELDING PROCESS

No exposed welds,
Good Neighbor profile - Same appearance on both sides

MONTAGE PLUS™ RAIL
Specially formed high strength architectural shape.

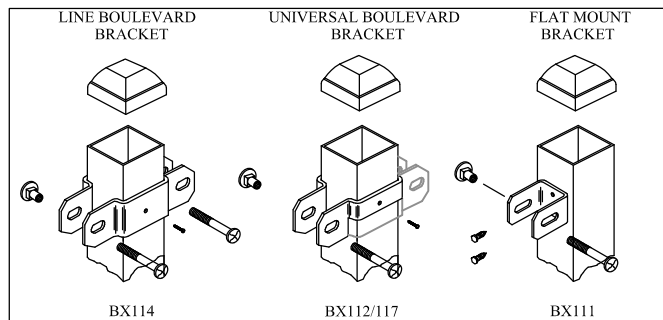
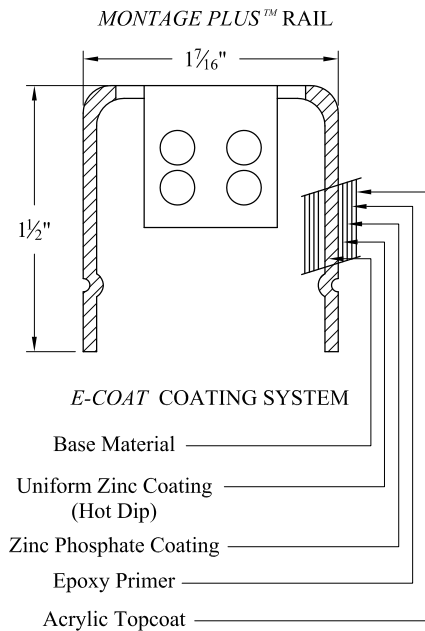

COMMERCIAL STRENGTH WELDED STEEL PANEL
PRE-ASSEMBLED

Values shown are nominal and not to be used for installation purposes. See product specification for installation requirements.

IRGISO

Title: **MONTAGE PLUS GENESIS 2/3-RAIL**

DR: CI	SH . 1 of 1	SCALE: DO NOT SCALE
CK: ME	Date 6/28/10	REV: e



AMERISTAR®

1555 N. Mingo
Tulsa, OK 74116
1-888-333-3422
www.ameristarfence.com