

RAIL JOINT DETAIL
DETAIL B

2" x 10" PRESSURE TREATED TOP RAIL

POST SLEEVE

6.5

RAILS ARE SECURED TO POST SLEEVES USING 4 - 5/16" CARRIAGE BOLTS AND WASHERS AND NUTS

POST SLEEVES ARE IS SECURED TO POST USING 2 - 1/4" BOLTS AND LOCK WASHERS

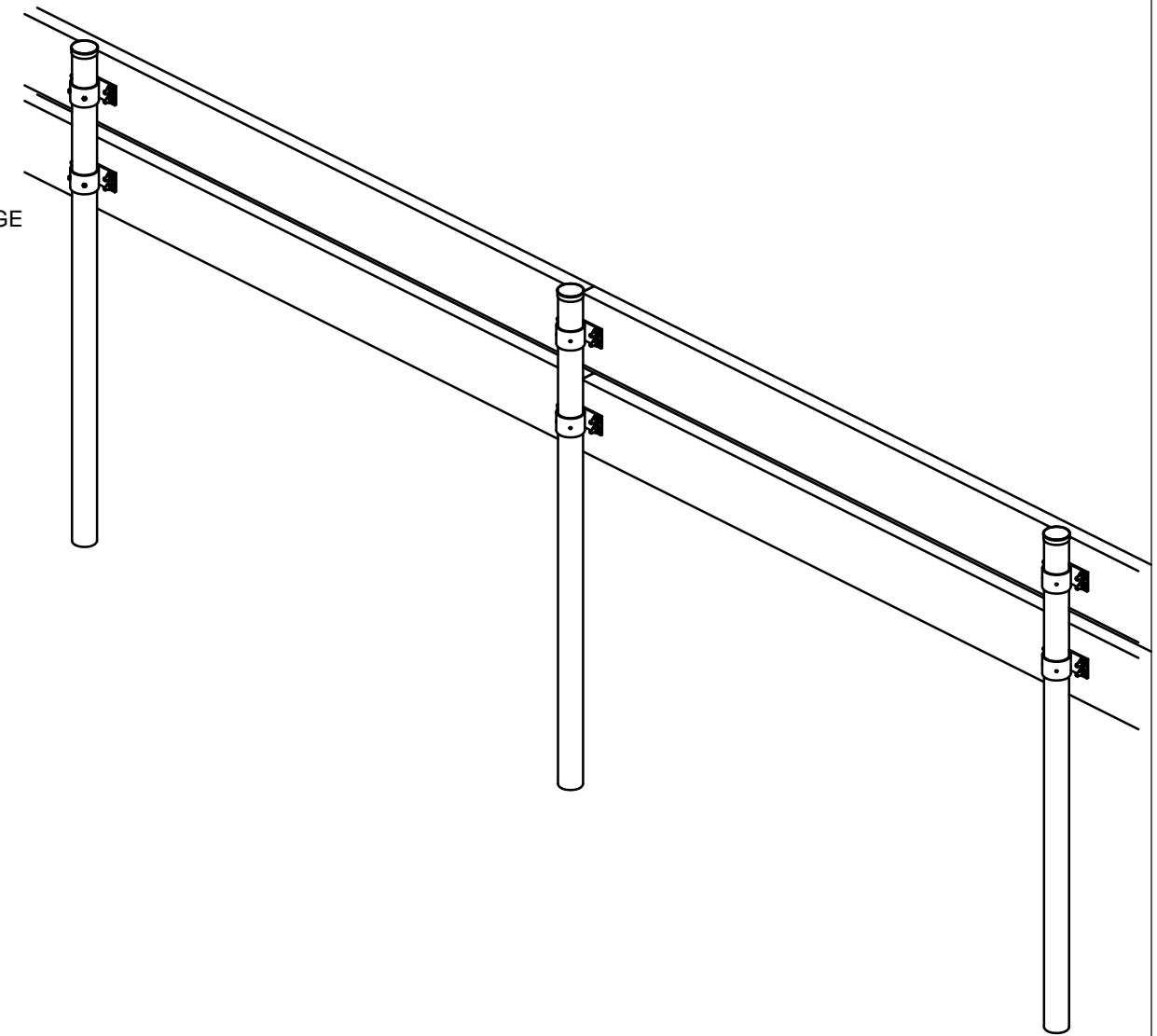

96.0

96.0

POST CAP

2" x 10" PRESSURE TREATED RAILS

14.0

36.0

GRADE

Ø3 1/2" SS40 GALVANIZED STEEL POST
ALL POSTS INSTALLED BY DRIVEN METHOD

48.0

STRAIGHT RUN POST SLEEVE

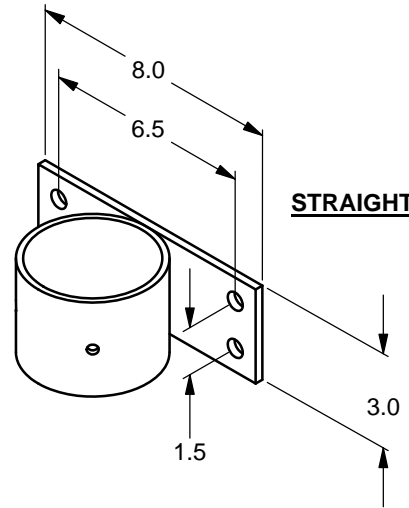

90 Lowson Crescent,
Winnipeg, Manitoba, Canada R3P 2H8
Phone: 1-800-406-2342
Fax: 1-204-284-1868
Web: www.wallacefences.com

Description:		3 FT. BUMPER FENCE	
		2 RAIL	
Customer / Project Name:		-	
Finish:	-	Date:	2/14/2012
Drawing No.	3BF-02-14-12	Rev.	-
		Sheet:	1 of 1