

**STANDARD LOCK - CHAIN LOCK**

1 FOOT OF 5/16" GALVANIZED CHAIN WELDED TO END OF BOTH BARRIER ARMS

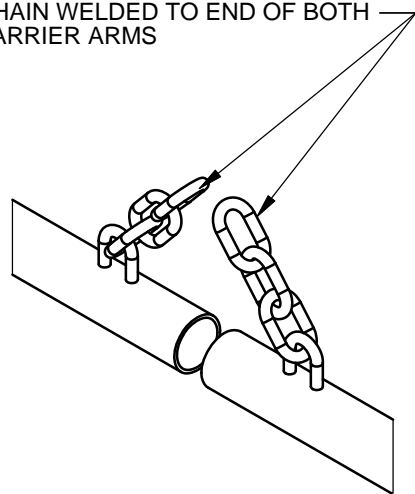

**OPTIONAL LOCK - FLIP LOCK**

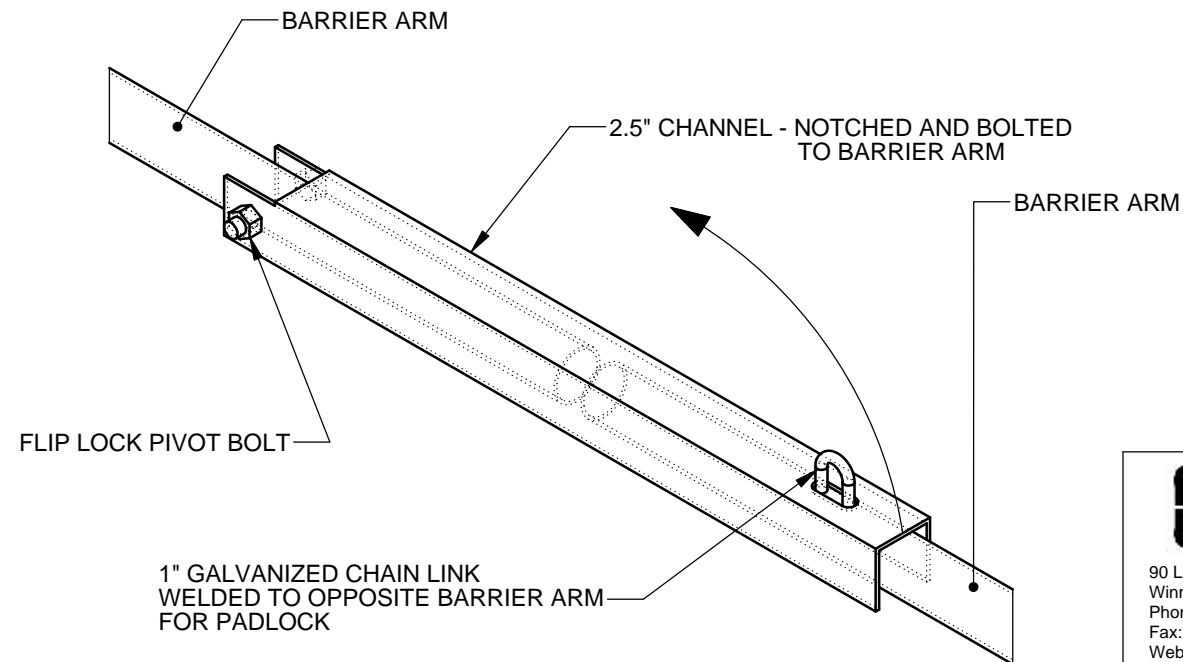

90 Lawson Crescent,  
Winnipeg, Manitoba, Canada R3P 2H8  
Phone: 1-866-406-2342  
Fax: 1-204-284-1868  
Web: www.wallacefences.com

Description:		<b>BARRIER ARM</b>	
Project / Customer Name:		-	
Finish:	HOT DIPPED GALVANIZED FINISH		Date:
Drawing No.	<b>BARRIER ARM</b>	Rev.	-
		Sheet:	1 of 1